

Self-operated Temperature Regulators

Temperature Regulator Type 1

with unbalanced single-seated globe valve · Flanges



Application

Temperature regulators for heating installations with control thermostats for set points from -10 to $+250$ °C · Nominal sizes DN 15 to 50 · Nominal pressure PN 16 to 40 · Suitable for temperatures up to 350 °C

The valve **closes** as the temperature rises.

Note

Typetested temperature regulators (TR), temperature limiters (TL), safety temperature monitors (STM) and safety temperature limiters (STL) are available.



The regulators consist of an unbalanced valve and a control thermostat, consisting of a temperature sensor, set point adjuster with excess temperature protection, capillary tube and operating element.

Special features

- Low-maintenance P regulators requiring no auxiliary energy
- Wide set point range and convenient set point adjustment indicated on a dial
- Unbalanced single-seated globe valves for use in applications with liquids, gases and vapors, especially for heat transfer fluids such as water, oil or steam
- Valve body optionally made of cast iron, spheroidal graphite iron, cast steel or cast stainless steel
- Versions with double adapter available for attachment of a temperature limiter or a second control thermostat. See Data Sheet T 2036 EN for details.

Versions

Type 1 Temperature Regulators

Nominal sizes DN 15 to 25 · PN 25 to 40 · DN 32 to 50 · PN 16 to 40 · Types 2231 to 2235 Control Thermostats

For details on the application of the control thermostats, refer to Information Sheet T 2010 EN.

Type 2111/2231 · With Type 2111 Valve and Type 2231 Control Thermostat for liquids · Set points from -10 to $+150$ °C · Set point adjustment at the sensor

Type 2111/2232 · With Type 2111 Valve and Type 2232 Control Thermostat for liquids and steam · Set points from -10 to $+250$ °C · Separate set point adjustment

Type 2111/2233 · With Type 2111 Valve and Type 2233 Control Thermostat for liquids, air and gases · Set points from -10 to $+150$ °C · Set point adjustment at the sensor

Type 2111/2234 · With Type 2111 Valve and Type 2234 Control Thermostat for liquids, air and gases · Set points from -10 to $+250$ °C · Separate set point adjustment

Type 2111/2235 · With Type 2111 Valve and Type 2235 Control Thermostat for air-heated storerooms, drying, climatic and heating cabinets · Set points from -10 to $+250$ °C · Separate set point adjustment and a sensor tube to be installed on site

Versions with screwed ends G $\frac{1}{2}$ to G1 female thread can be found in Data Sheet T 2112 EN

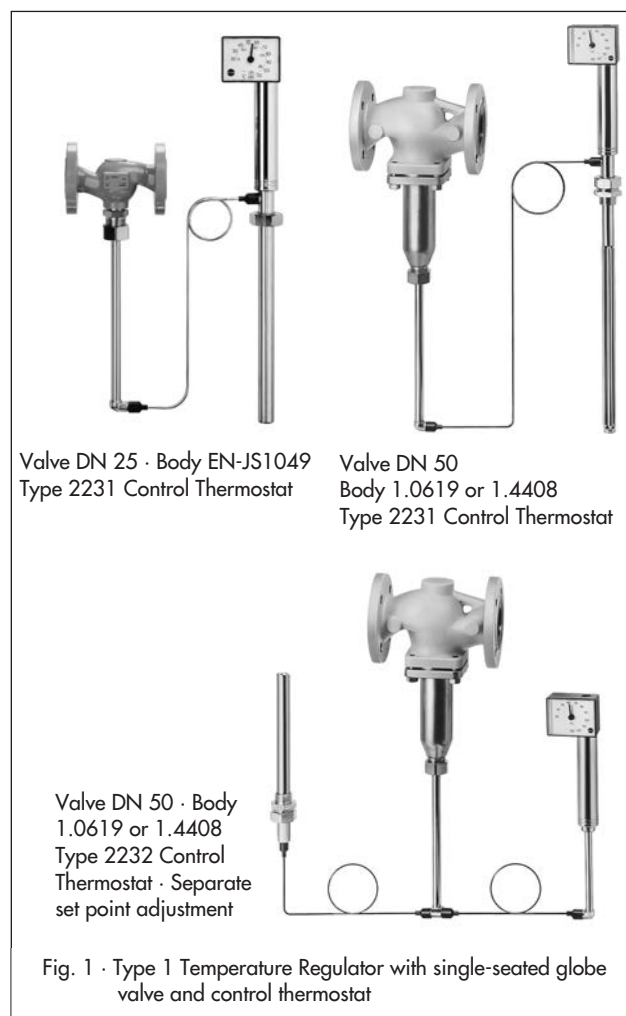

Fig. 1 · Type 1 Temperature Regulator with single-seated globe valve and control thermostat

Special version

- 5 m, 10 m or 15 m capillary tube
- Sensor made of CrNiMo steel
- Capillary tube made of CrNiMo steel or plastic-coated copper
- Valve free of non-ferrous metal
- Valve in corrosion-resistant version
- ANSI version (see Data Sheet T 2115 EN)

Principle of operation (see Fig. 2)

The regulators operate according to the liquid expansion principle. The temperature sensor (11), capillary tube (8) and operating element (7) are filled with an expanding liquid. The liquid changes its volume depending on the temperature, causing the operating element (7) and the plug stem (5) with the plug (3) of the valve to move.

The position of the plug determines the flow rate of the heat transfer medium across the area released between the plug (3) and seat (2).

The temperature set point can be adjusted with a key (9) to a value that can be read off the dial (10).

Valve

- 1 Valve body
- 2 Valve seat (exchangeable)
- 3 Valve plug
- 4 Lower part (only for 1.0619 and 1.4408)
- 5 Plug stem with spring

Control thermostat

- 6 Connection for operating element (coupling nut)
- 7 Operating element with bellows
- 8 Capillary tube
- 9 Key for set point adjustment
- 10 Set point dial
- 11 Temperature sensor (bulb sensor)

Installation

• Valve

Install the valves in horizontal pipelines. The direction of flow must correspond with the arrow on the body. The connecting element must be vertically suspended.

• Capillary tube

Install the capillary tube such that it is not exposed to considerable temperature fluctuations and cannot be damaged. Make sure the permissible ambient temperature range is not exceeded. The smallest possible bending radius is 50 mm.

• Temperature sensor

The temperature sensor can be installed in any desired position. Nevertheless, its entire length must be immersed in the process medium. Choose a place of installation where neither overheating nor considerable idle times occur.

Only use the same kind of materials together. For example, thermowells made of stainless steel 1.4571 can be installed in stainless steel heat exchangers.

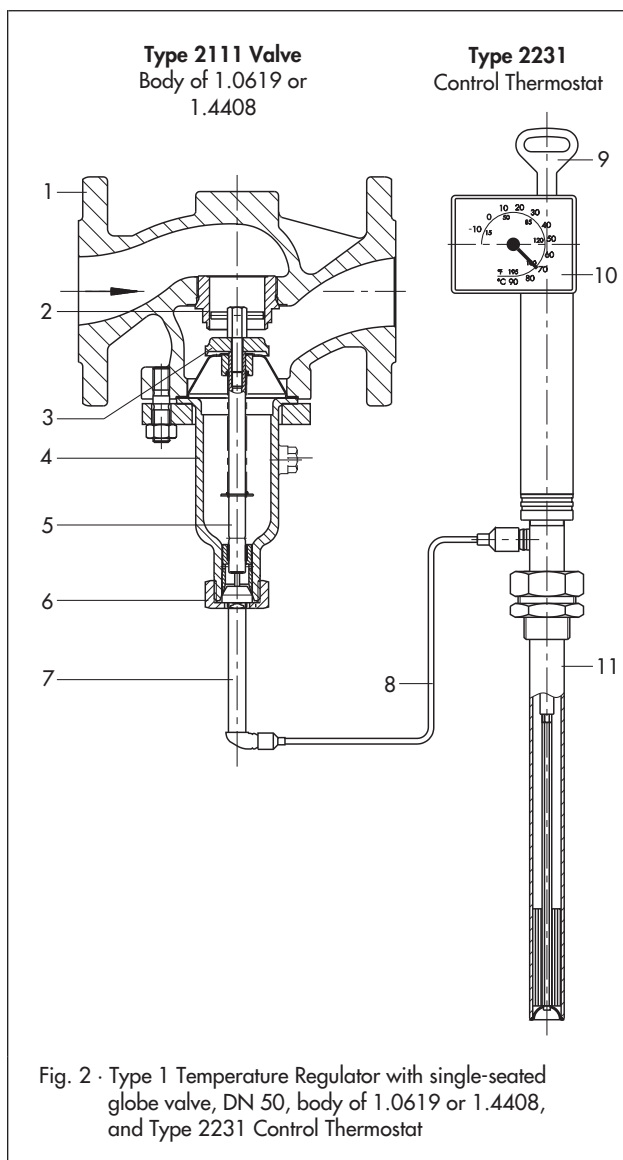

Fig. 2 · Type 1 Temperature Regulator with single-seated globe valve, DN 50, body of 1.0619 or 1.4408, and Type 2231 Control Thermostat

Table 1 · Technical data · All pressures in bar (gauge)

The specified permissible pressures and differential pressures are limited by the specifications in the pressure-temperature diagram and the pressure ratings (acc. to DIN EN 12516-1).

Type 2111 Valve							
Nominal pressure	PN 16 to PN 40						
K _V s, leakage rate and max. permissible differential pressures Δp in bar							
Standard version	DN	15	20	25	32	40	50
K _V s coefficient		4	6.3	8	16	20	32
Differential pressure	Δp_{\max}	25 ¹⁾	16 ¹⁾	14	6	6 ²⁾	4
Leakage rate acc. to IEC 60534-4	≤ 0.05% of K _V s coefficient						
Special version	DN	15	20	25	32	40	50
K _V s coefficient		2.5 · 1 · 0.4 · 0.1		4 ¹⁾ · 1 · 0.4 · 0.1	6.3 ¹⁾	8	16
Diff. pressure	Δp_{\max}	25			16	14	6
Permissible valve temperature	Max. 350 °C · See pressure-temperature diagram (T 2010 EN)						
Types 2231 to 2235 Thermostats							
Size 150							
Set point range (set point span 100 K)	-10 to +90 °C, 20 to 120 °C, or 50 to 150 °C For Types 2232, 2234, 2235 also 100 to 200 °C, 150 to 250 °C						
Permissible ambient temperature at the set point adjustment head	-40 to +80 °C						
Permissible temperature at the sensor	100 K above the adjusted set point						
Permissible pressure at the sensor	Type 2231/2232	Without thermowell: PN 40 · With thermowell: PN 40/PN 100 With thermowell with flange: PN 40/PN 100					
	Type 2233/2234	Without thermowell: PN 40 · With flange PN 6/PN 40					
Length of the capillary tube	3 m (special version: 5 m, 10 m or 15 m)						

¹⁾ For EN-JS1049: $\Delta p_{\max} = 14$ bar · ²⁾ In conjunction with Type 2212 STM: 4 bar

Table 2 · Materials · Material numbers according to DIN EN

Type 2111 Valve				
Nominal size	DN 32 to 50	DN 15 to 50		
Nominal pressure	PN 16	PN 25	PN 40	
Body	Cast iron EN-JL 1040	Spheroidal graphite iron EN-JS 1049	Cast steel 1.0619	Cast stainless steel 1.4408
Seat and plug	1.4305		1.4104/1.4112	1.4571
Plug stem/spring	1.4301/1.4310			
Lower part	1.0425 ¹⁾			1.4571
Body gasket	Graphite on metal core			
Extension piece/ separating piece	Brass (special version: stainless steel 1.4301)			1.4301
Types 2231, 2232, 2233, 2234 and 2235 Thermostats				
	Standard version	Special version		
Operating element	Nickel-plated brass			
Type 2231/2232	Nickel-plated bronze	Stainless steel 1.4571		
Sensor Type 2233/2234	Nickel-plated copper			
Type 2235	Copper	-		
Capillary tube	Nickel-plated copper	Plastic-coated copper or stainless steel 1.4571		
Thermowell				
with threaded connection G 1				
Immersion tube	Nickel-plated bronze · Nickel-plated steel	Stainless steel 1.4571		
Threaded nipple	Nickel-plated brass · Nickel-plated steel	Stainless steel 1.4571		
... with flange				
Immersion tube	Steel	Stainless steel 1.4571		
Flange	Steel	Stainless steel 1.4571		

¹⁾ EN-JL 1040 and EN-JS 1049 with brass bushing

Flow rate diagram for water

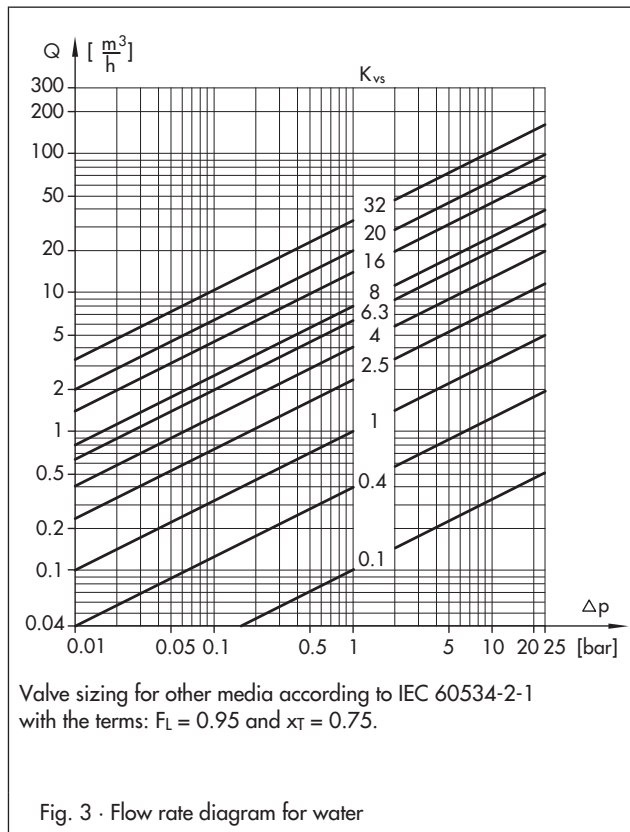

Accessories

Thermowells with threaded connection or flange for bulb sensors (Type 2231 or Type 2232) · Threaded connection G 1, PN 40, made of bronze, steel or CrNiMo steel · Flange DN 32, PN 40, with immersion tube made of stainless steel or steel · Immersion tube made of PTFE, PN 6 (flange PN 40)

Thermowell for flammable gases **typetested by DVGW** (German Technical and Scientific Association on Gas and Water), threaded connection G 1, PN 100

Mounting parts for Type 2233 and Type 2234 · Brackets for wall mounting · Cover for thermostat

To protect the operating element from inadmissible operating conditions, an **extension piece** or **separating piece** must be installed between the valve and the operating element.

An **extension piece** is needed for temperatures over 220 °C. The standard version does not have sealing.

The special version of the extension piece is made of stainless steel and has a bellows seal. It additionally acts as a separating piece.

An extension piece is required for temperatures over 150 °C when valves with cast iron or spheroidal graphite iron bodies are used together with Type 2212 Safety Temperature Limiter or Type 2213 Safety Temperature Monitor.

A **separating piece** is made of brass (for water and steam) or CrNi steel (for water and oil).

A separating piece must be used when a seal between thermostat and valve is required. Separating pieces made of CrNi steel must be used when all wetted parts are to be free of non-ferrous metals.

In addition, it prevents the medium from leaking while the thermostat is being replaced.

Also available:

Safety temperature monitors (STM) and **safety temperature limiters (STL)**. For details refer to Data Sheets T 2043 EN and T 2046 EN.

Typetested safety equipment

The register no. is available on request.

Temperature regulators (TR) with a Type 2231, 2232, 2233, 2234 or 2235 Thermostat and a Type 2111 Valve in nominal sizes DN 15 to 50.

Sensor without thermowell: up to 40 bar

Sensor with thermowell: only in SAMSON version G 1, bronze and 1.4571 up to 40 bar

DVGW-typetested thermowells for flammable gases, threaded connection G 1, PN 100

For further details on typetested devices see Data Sheet T 2040 EN.

Dynamic behavior of the thermostats

The dynamics of the regulator are mainly determined by the response of the sensor with its characteristic time constant.

Table 3 lists the response times of SAMSON sensors operating on different principles when tested in water.

Table 3 · Time constants of SAMSON thermostats

Functional principle	Type ... Control Thermostat	Time constant in seconds	
		Without thermowell	With thermowell
Liquid expansion	2231	70	120
	2232	65	110
	2233	25	-1)
	2234	15	-1)
	2235	10	-1)
	2213	70	120
Adsorption	2213	-1)	40

1) Not permissible

Table 4 · Dimensions in mm and weights

Type 2111 Valve		DN	15	20	25	32	40	50
Length L			130	150	160	180	200	230
Body material of cast iron (EN-JS 1040) and spheroidal graphite iron (EN-JL 1049)								
H1			82			152		
H			372			442		
Weight (body PN 16)		Approx. kg	4			10 ¹⁾		
Body material of cast steel (1.0619) and stainless steel (1.4408)								
H1		Without extension piece				225		
		With extension piece				365		
H		Without extension piece				515		
		With extension piece				655		
Weight		Approx. kg	4	4.5	5.5	10 ¹⁾	11.5 ¹⁾	13.5 ¹⁾
Thermostat		Type	2231	2232	2233	2234	2235	
Immersion depth T			290 ²⁾	235 ²⁾	430	460	3460	
Weight		Approx. kg	3.2	4.0	3.4	3.7	3.6	

¹⁾ Body PN 16; +15 % for PN 25/PN 40 · ²⁾ Larger immersion depths available on request

Dimensions in mm · Valves and control thermostats

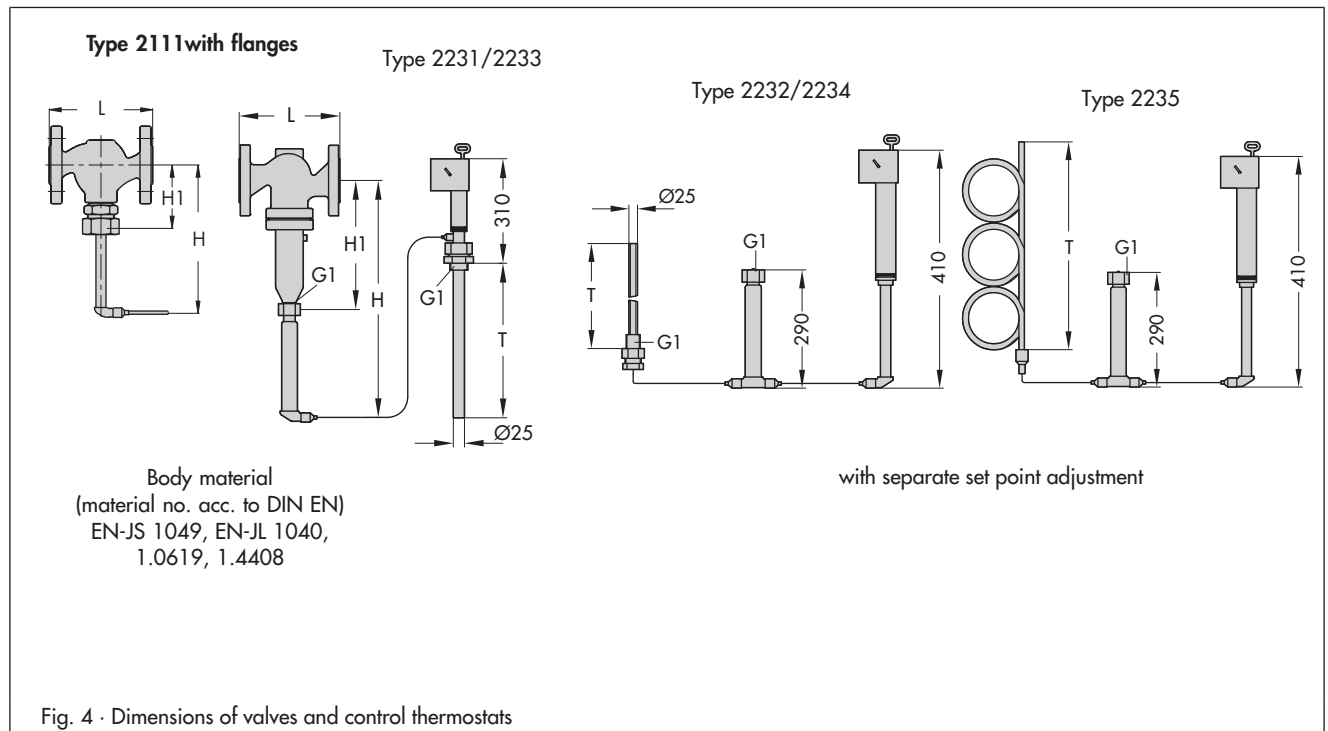

Fig. 4 · Dimensions of valves and control thermostats

Ordering text

Temperature Regulator Type 1

DN ..., PN ...

Body material

With Control Thermostat Type ..., set point range ...°C

Capillary tube ... m

Special version, if required

Accessories

Conversion of valve sizing coefficients

$$C_V \text{ (in US gallons/min)} = 1.17 \cdot K_{VS} \text{ (in m}^3\text{/h)}$$

$$K_{VS} \text{ (in m}^3\text{/h)} = 0.86 \cdot C_V \text{ (in US gallons/min)}$$

Thermowells for Types 2231/2232

Control thermostat	Type 2231	Type 2232
Immers. depth T2 in mm	325	250

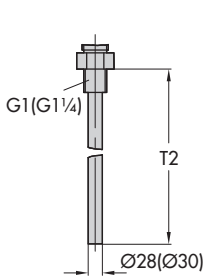

Threaded connection
G 1/PN 40 or PN 100
PN 100 (dimensions in parentheses)

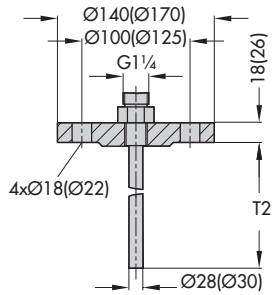

Flanged connection
DN 32/PN 40
DN 40/PN 100
(dimensions in parentheses)

Thermowells for flammable gases (PN 100/PN 63)

Control thermostat	Type 2231	Type 2232
Length L1	mm 315	mm 255
Length L2	mm 340	mm 280

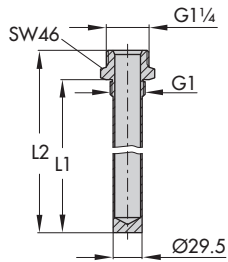

Thermowell for flammable gases
G 1/PN 100

Clamps and perforated cover for wall mounting

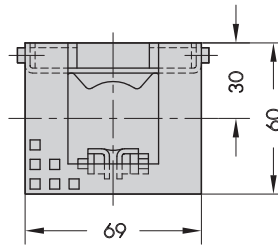
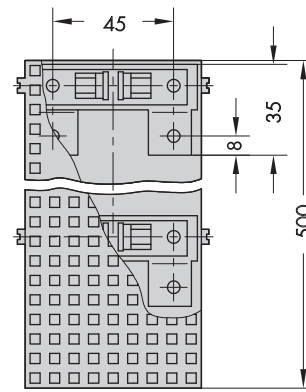

Extension piece/ separating piece

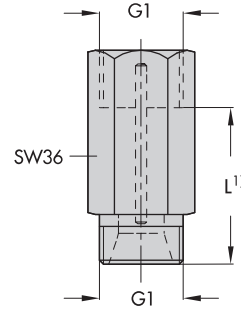

Extension piece:
Standard version
L = approx. 140 mm,
approx. 0.5 kg
Special version (with bellows seal)
L = approx. 180 mm,
approx. 0.6 kg
Separating piece:
with seals
approx. L = 55 mm,
approx. 0.2 kg

¹⁾ When accessories are used, the H and H1 increase by the dimension L

Flange for Type 2233 and Type 2234

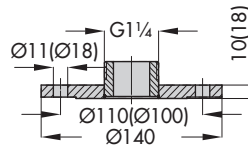

Flange PN 6, 140 outside Ø

Flange PN 40/DN 32
(dimensions in parentheses)

Fig. 5 · Dimensions of accessories

Specifications subject to change without notice.

