

Electrically Controlled On-Off Deluge Valve with Electric Remote Reset Latch

Model: FP 400E-3D-RL

Description

The BERMAD 400E-3D-RL Deluge Valve is suitable for use with remote controlled or/and automatic water spray or foam deluge systems that include electric detection and piping systems with open nozzles.

This BERMAD Deluge Valve is equipped with two solenoid valves and Double-Acting Relay Valve (DRV) which trips the deluge valve into an open position during the Opening solenoid activation. The valve will then latch in its last position. The 400E-3D-RL will reset remotely via short pulse to activate the Closing solenoid coil.



UL LISTED

Typical Applications

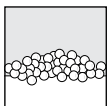

Water/foam fire systems



Deluge & spray systems

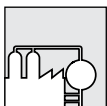

Petrochemical facilities



Flammable materials storage

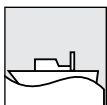

Marine environments

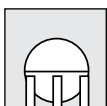

Gas storage tanks

Features and Benefits

- **Low Power DC Current** – Suitable as battery backup
- **Electric Remote Reset Latch (RL)** – Safety feature
- **Latched at Last Position** – Safer and energy-saving
- **One-piece molded elastomeric moving part** – No maintenance required
- **Obstacle-Free Full Bore** – Uncompromising reliability
- **Factory Pre-Assembled Trim** – Out-of-box quality
- **In-Line Serviceable** – Minimal downtime

Optional Features

- **Solenoids for hazardous locations**
- **Limit Switch for hazardous locations**
- **Alarm Pressure Switch for hazardous locations**
- **Foam Concentrate Configuration (FC prefix)**
- **Valve Position Single/Double Limit Switches**

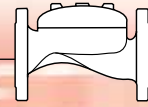

Operation

In the SET position, water pressure is supplied to the BERMAD Deluge Valve control chamber [1] via the priming line [2], Restriction Orifice [3] and through a DRV [4] Double-Acting Relay Valve. The Deluge Valve is trapped by the Check Valve [5]. The trapped water pressure holds the main valve's diaphragm and plug against the valve seat, creating a tight shutoff and keeping the system piping dry. The DRV remains in its last position supplying water pressure to the control chamber with both solenoid coils de-energized. This keeps the BERMAD Deluge Valve closed.

In fire or test conditions, the electric control system transmits an electric pulse that triggers the Opening Solenoid Coil [S1], which in turn activates the DRV to switch to the Release position. Pressure is then released from the Deluge Valve control chamber, allowing water to flow into the system piping and to the alarm device. The valve can also be operated via the Local Manual Emergency Release [6].

After operation, the DRV ensures that the BERMAD Deluge Valve will latch in its Open Position. The valve will reset remotely via short pulse which activates the Closing Solenoid Coil [S2] and causes the DRV to shift to the normal supply position.

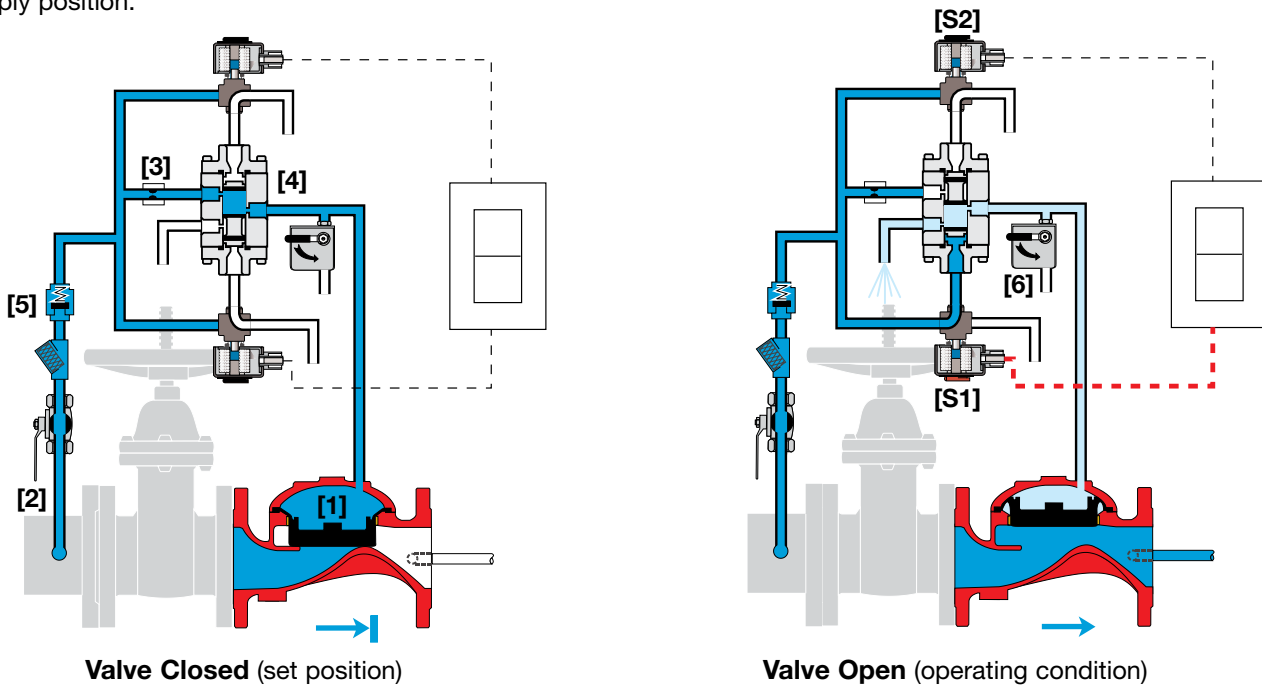

Engineer Specifications

- The Deluge Valve shall be Electrically Controlled On-Off with Remote Reset Latch feature specifically UL-Listed as such.
- The Deluge Valve shall be an elastomeric globe type of unobstructed flow path, with no stem guide or supporting ribs. The valve actuation shall be accomplished by a single piece rolling-diaphragm, with a rugged radial seal disk. The diaphragm assembly shall be the only moving part. The valve shall have a removable cover for quick in-line service enabling all necessary inspection and servicing.
- The valve operation will be On-Off Control type, using separate electric pulse to operate and close the Deluge Valve to enable Latched Opening With Electrically Remote Reset.
- The control trim shall be pre-assembled and shall include a Dual 3-Way Solenoid valve, DRV (Double-Acting Relay Valve), Y strainer and Manual Emergency Release.
- The control trim shall be pre-assembled with the main Deluge Valve and hydraulically tested at the manufacturer's ISO 9000 and 9001 certified factory prior to shipment.
- The Deluge Valve will be locked (latched) in its last position and Reset Remotely in response to an electric signal activating the closing solenoid coil.

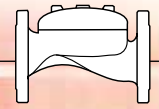

System Components

- 1 - Main Valve, BERMAD FP 400E Series
- 2B - Priming Restriction
- 4B - Priming Strainer
- 7B - Check Valve
- 15B - Manual Emergency Release
- 18B - Priming Ball Valve
- 24B - 3-Way Solenoid Valve
- 26 - Double-Acting Relay Valve (DRV)
- JB - Junction Box, ½"NPT Entry

Optional

- S - Valve Position Limit Switch / Switches
- I - Visual Position Indicator
- P - Pressure Switch

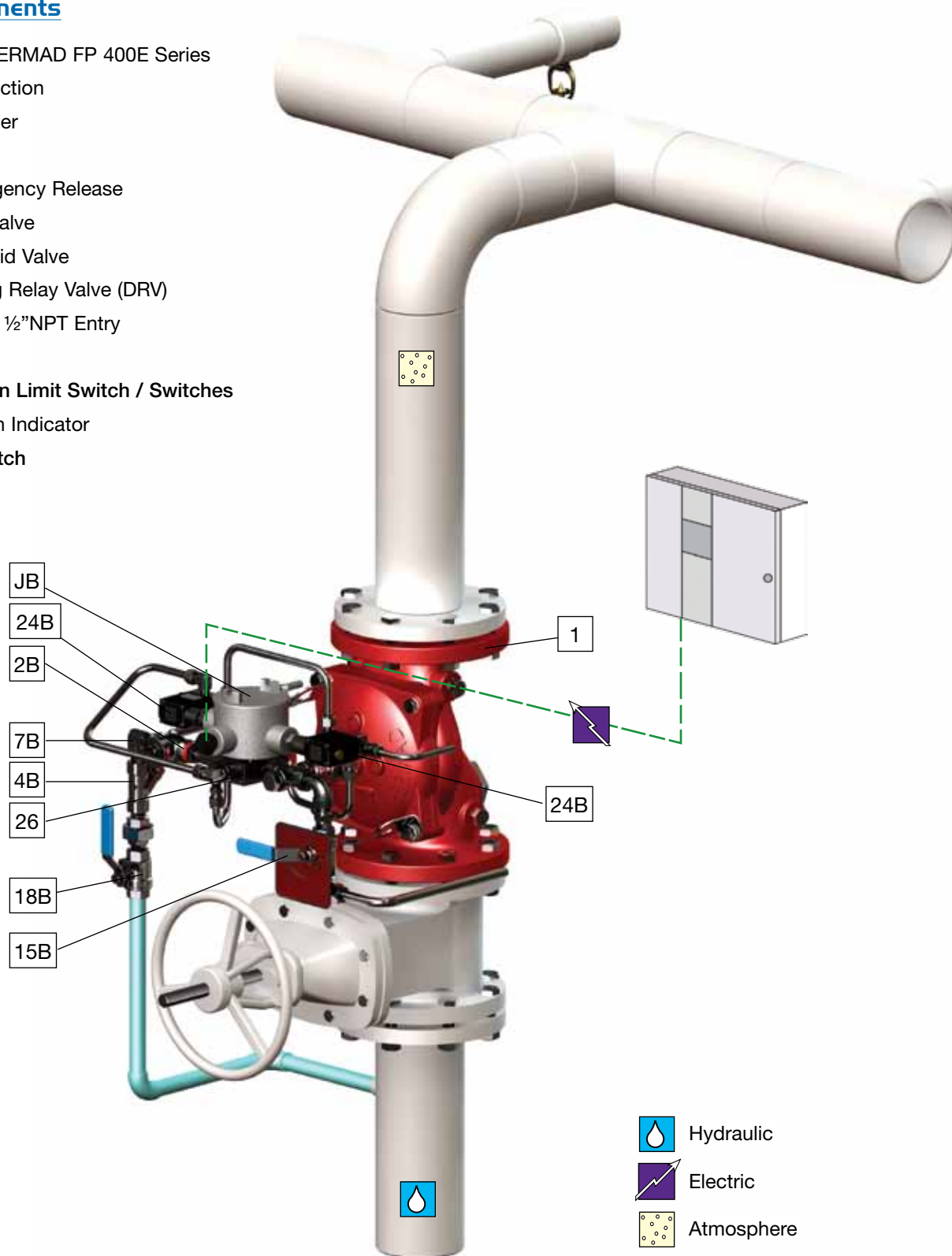

Note

The BERMAD Model FP 400E-3D-RL is UL-Listed when installed with specific components and accessories.

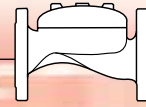

Technical Data

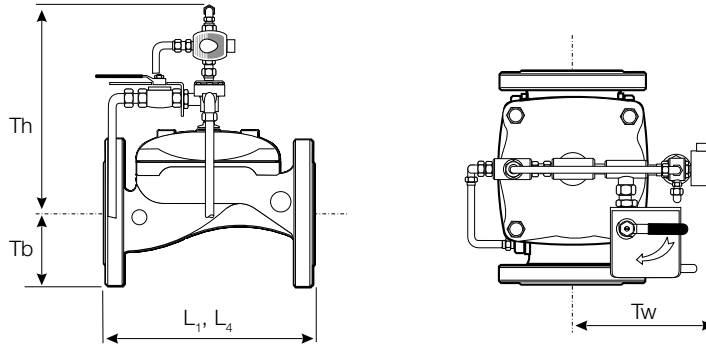

Size	1½"		2"		2½"		3"		4"		6"		8"		10"		12"		
	mm	inch	mm	inch	mm	inch	mm	inch	mm	inch	mm	inch	mm	inch	mm	inch	mm	inch	
Dimensions	L ₁ ⁽¹⁾	205	8 ¹ / ₁₆	205	8 ¹ / ₁₆	205	8 ¹ / ₁₆	257	10 ² / ₁₆	320	12 ¹⁰ / ₁₆	415	16 ⁵ / ₁₆	500	19 ¹¹ / ₁₆	607	23 ¹⁴ / ₁₆	725	28 ⁹ / ₁₆
	L ₄ ⁽²⁾	N/A	N/A	205	8 ¹ / ₁₆	N/A	N/A	257	10 ² / ₁₆	320	12 ¹⁰ / ₁₆	415	16 ⁵ / ₁₆	500	19 ¹¹ / ₁₆	N/A	N/A	N/A	N/A
	Tw	255	10 ¹ / ₁₆	255	10 ¹ / ₁₆	255	10 ¹ / ₁₆	255	10 ¹ / ₁₆	255	10 ¹ / ₁₆	255	10 ¹ / ₁₆	255	10 ¹ / ₁₆	255	10 ¹ / ₁₆	255	10 ¹ / ₁₆
	Tb	64	2 ⁸ / ₁₆	78	3 ¹ / ₁₆	89	3 ⁸ / ₁₆	100	3 ¹⁵ / ₁₆	115	4 ⁸ / ₁₆	140	5 ⁸ / ₁₆	172	6 ¹² / ₁₆	204	8 ¹ / ₁₆	242	9 ⁸ / ₁₆
	Th	289	11 ⁶ / ₁₆	289	11 ⁶ / ₁₆	301	11 ¹⁴ / ₁₆	325	12 ¹³ / ₁₆	345	13 ⁹ / ₁₆	420	16 ⁹ / ₁₆	471	18 ⁹ / ₁₆	471	18 ⁹ / ₁₆	588	23 ² / ₁₆

- Notes:**
- L₁ is for flanged ANSI #150 and ISO PN16.
 - L₄ is for grooved end connections (Ductile Iron Only).
 - Provide adequate space around valve for maintenance.
 - Data is for envelope dimensions, specific component positioning may vary.

Connection Standard

- Flanged: ANSI B16.42 (Ductile Iron), B16.5 (Steel & Stainless Steel), B16.24 (Ni. Al. Bronze)
- ISO PN16
- Grooved: ANSI/AWWA C606 for 2, 3, 4, 6 & 8"

Water Temperature

- 0.5 – 50°C (33 – 122°F)

Approvals

- UL-Listed for sizes 1½, 2, 2½, 3, 4, 6, 8 & 10"
- ABS and Lloyds Register approved, sizes 1½, 2, 2½, 3, 4, 6, 8, 10 & 12"

Pressure Rating*

- Max. for Class #150/PN16: 250 psi (17 bar)

Electrical Requirements

- Operation to open/close by 3 wires (dual coil), 0.45 amp rating
- Minimum pulse period: 100 ms to open and 100 ms to close the valve.

* Pressure rating might be limited due to solenoid valve rating

Manufacturers Standard Materials

Main valve body and cover

- Ductile Iron ASTM A-536

Main valve internals

- Stainless Steel 304 & Cast Iron

Control Trim System

- Brass control components/accessories
- Stainless Steel 316 tubing & fittings

Elastomers

- Nylon fabric reinforced polyisoprene NR

Coating

- Electrostatic Powder Coating Polyester, Red (RAL 3002)

Optional Materials

Main valve body

- Carbon Steel ASTM A-216 WCB
- Stainless Steel 316 CF8M
- Ni-Al-Bronze ASTM B-148

Control Trim

- Stainless Steel 316
- Monel® and Al-Bronze
- Hastalloy C-276

Elastomers

- NBR
- EPDM

Coating

- High Build Epoxy Fusion-Bonded with UV Protection, Anti-Corrosion

Solenoid Valves

Standard

- 2 units 3-way, direct acting, continues duty
- Enclosure: General purpose watertight, NEMA 4 / IP65, Class F
- Power: 24VDC, 8 watts
- UL – Listed

Options (see also ordering guide)

- Hazardous locations:
 - Class I Division 1, Gr. A, B, C, D, T4 (code 7)
 - Class I Division 2, Gr. A, B, C, D, T4
 - ATEX, EEx d IIC T6 (code 9)
- Voltage: see ordering guide (voltage options)
- Stainless Steel 316 body material (code K)

Optional Instrumentations

- Proximity Limit switches (Explosion proof)
- Alarm Pressure switch
- Pressure Indicators
- Valve Visual Position Indicator Stem

